

# Kraftmessgerät NG-Serie ohne Loch und 100 mm Anzeige



**ATP Messtechnik GmbH**

J. B. von Weiss Strasse 1

D- 77955 Ettenheim

Email: info@atp-messtechnik.de

Internet: www.atp-messtechnik.de

Tel: 0 7822-8624 0 - FAX: 0 7822-8624 40

## Hydraulic Force Gauge Model NG-10/20/80



Beschreibung	Description
<p>Hydraulische Kraftaufnehmer/ Kraftmessdosen, arbeiten nach dem Prinzip, dass die auf den Kolben wirkende Kraft – entsprechend der Kolbenfläche – in einen hydraulischen Druck umgewandelt wird und über das Messorgan, analog, als Krafteinheit skaliert, angezeigt wird.</p> <p>Messsysteme dieser Art sind für statischen bzw. quasistatischen Einsatz bestens geeignet. Durch die Unabhängigkeit von einer Stromquelle bieten sie für unterschiedliche Anwendungsbereiche ideale Einsatzgebiete (so z.B. in der Luft- und Raumfahrt).</p> <p>Die Kraftanstiegs- und Abfallzeit sollte mindestens 0,5 s betragen, eventuell bei der Be- oder Entlastung auftretende Schläge können jedoch mit speziellen Drosseln gedämpft werden (Option).</p> <p>Das Gehäuse des NG-10/20/80 muss ganzflächig aufliegen, der pendelnde Kolben gleicht Unebenheiten bis max. 3° aus.</p>	<p>Hydraulic force gauges working according the principle, that the force effective on the piston is converted into a hydraulic pressure, whereby the analogue result is displayed on a dial gauge, scaled in a force value.</p> <p>Systems working on the hydraulic principle are used for static or quasi- static applications. Especially in view of independence of a voltage supply, it can be used in a wide range of applications (e.g. aerospace industry).</p> <p>The increasing and decreasing time of the force has to be min. 0.5 sec. peaks occurring during loading or relief can, however, be damped with special chokes (Optional).</p> <p>The housing of the NG-10 usw should fit over the entire area, whereby the piston compensates unevenness up to 3°.</p>

Wesentliche Merkmale	Characteristics
Messbereiche von 160 N ... 630 kN	Measuring ranges from 160 N ... 630 kN
Anzeigebereich 10 ... 100%	Display range 10 ... 100%
Messgenauigkeit $\leq \pm 2\%$ v.E.	Accuracy $\leq \pm 2\%$ of end value (f.s.)
Temperaturbereich: 0 ... 50°C	Temperature range: 0 ... 50°C
Integrierter Schleppeizer	Integrated peak holder
Zur Kontrollmessung von Druckkräften	For measuring of compression forces

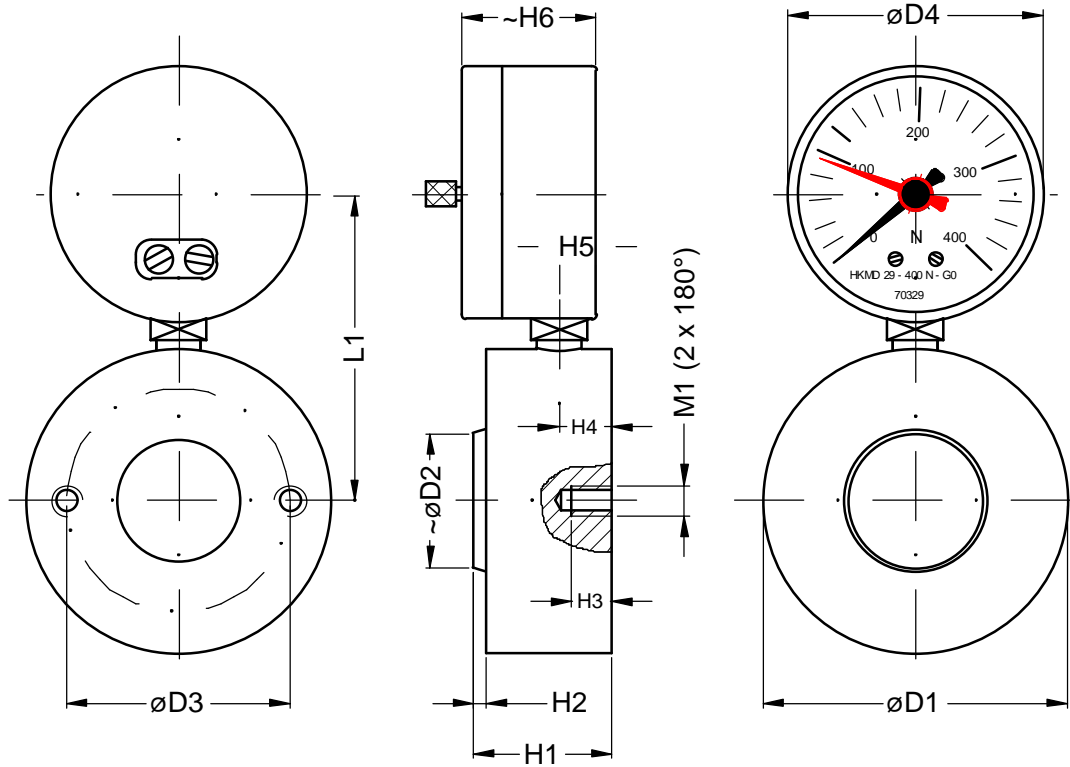

Modell	Größe / size	Hochdruckschlauch (m)	Kapillarrohr (m)	Gewicht / weight (kg)	Abmessungen (mm) / Dimensions (mm)												Bohrungsanzahl
					D1	D2	D3	D4	H1	H2	H3	H4	H5	H6	L1	M1	
Nennlast																	
160 N	0		0,5	1,7	75	34	55	63	30	3	10	14	12,5	32	82	M6	2
250 N																	
400 N																	
630 N																	
1 kN																	
1,6 kN		1	2,5														
2,5 kN																	
4 kN																	
6,3 kN																	
10 kN																	
16 kN	1	2,5	2	90	55	75	63	32	3	10	14	12,5	32	90	M8	2	
25 kN																	
40 kN																	
40 kN																	
63 kN																	
100 kN																	
100 kN	2	2,5	5,3	145	112	130	63	38	4	10	16	15	49	116	M8	2	
160 kN																	
250 kN																	
400 kN																	
400 kN																	
630 kN																	5,6